

2018 St Andrew's Program

COME WHAT MAY (J8x32) 2C (4C set) Romaine Butterfield RSCDS Book 51

- 1- 8 1M+2L Adv&Ret. 1M+2L dance DoSiDo
- 9-16 1L+2M repeat bars 1-8
- 17-24 1s cross RH, cast (2s step up 19-20). 2s cross RH cast (1s step up 23-24)
- 25-32 1s+2s Adv&Ret. 1s+2s dance ½ R&L

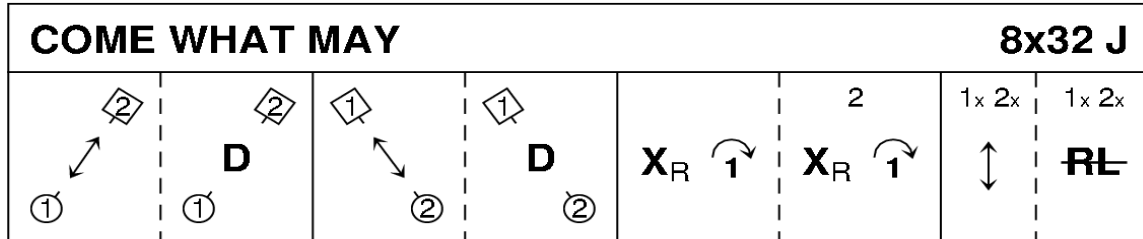

Romaine Butterfield, 2010, RSCDS Book 51

2C/4C longwise set.

THE HAAR ON SKYE (S8x32) 3C (4C set) Marilyn Watson RSCDS Graded 3

- 1- 8 1s+2s circle 4H round and back
- 9-16 1s cross down, giving RH, between 2s, cast round 3s, cross RH up between 3s, & cast up behind 2s, meet in middle, 1st place facing down, 2s step in to face 1s
- 17-24 1s+2s dance the Rondel with 1s finishing in 2nd place facing down
- 25-32 2s+1s+3s dance Grand Chain

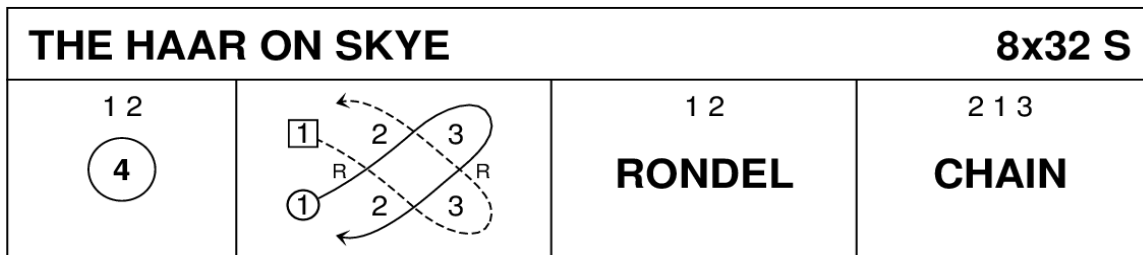

Marilyn Watson, 1997, Stepping Out 3, RSCDS Graded Book 3.7

3C/4C longwise set.

MORE BEES A-DANCING (R8x32) 3C (4C set) Roy Goldring G and S Dances 2

- 1- 8 1s lead down for 4 steps (2s step up bars 3-4), set and lead back up to face Man's 2nd corner (2L) in prom hold
- 9-16 1s dance diagonal RSh reel of 3 with 2nd corners and end facing Lady's 1st corner (2M)
- 17-24 1s dance LSh reel of 3 with 1st corners and ending in the middle (Man on Men's side facing partner)
- 25-32 1s set in middle, petronella turn to 2nd place own sides and 2s+1s+3s turn RH (4 bars)

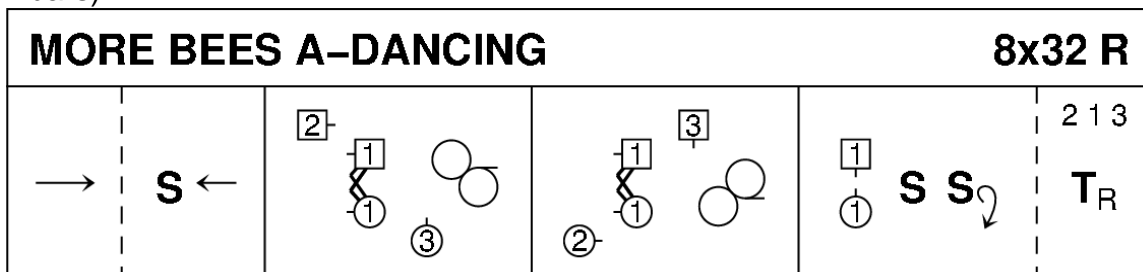



Roy Goldring, Graded and Social Dances 2

3C/4C longwise set.

ST ANDREW'S FAIR (J8x32) 3C (4C set) Roy Goldring 5 SCDs

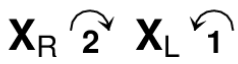
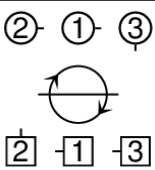
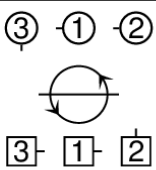
- 1- 8 1s cross RH, cast 2 places, cross LH below 3s and cast up to 2nd place own sides
- 9-16 2s+1s+3s ½ turn RH retain hands and all set (M face down and L up) 2L leads Ladies across and down own side while 3M leads Men across and up
- 17-24 3s+1s+2s circle 6H round and back
- 25-32 3s+1s+2s ½ turn LH retain hands and all set (M face up and L down) 2L leads Ladies across and up own side while 3M leads Men across and down. 213



St ANDREW'S FAIR			8x32 J		
	<p>2 1 3</p> <p>T_R¹ S</p> <p>retain hands</p> 	<p>3 1 2</p> <p>6</p>	<p>3 1 2</p> <p>T_L¹ S</p> <p>retain hands</p> 	<p>③ - ① - ②</p>  <p>③ - ① - ②</p>	

R Goldring, 1980, RSCDS 5/1982

3C/4C longwise set.

MOUNT MAXWELL STRATHSPEY (S3x32) 3C Wes Clindinning Saltspring Island 2007

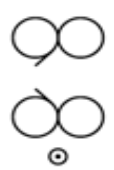
- 1 -8 1s+2s+3s reel of three on the sides, 1L giving left shoulder to 2L and 1M giving right shoulder to 2M.
- 9-16 All couples set, turn partners 2H twice and set
- 17-24 1s followed by 2s, lead down the middle. 2s divide and follow 1s back to top. Both couples finish in the middle ready for
- 25-32 1s+2s Allemande. On bars 31 & 32, 1s casts to 3rd place, 3s dance into 2nd place.



MOUNT MAXWELL STRATHSPEY			3x32 S
	<p>ALL</p> <p>S T_{B2} S</p>	<p>1 2</p> 	<p>1 2</p> <p>A </p>

W. Clindinning, Saltspring Island 2007

3C/3C longwise set.

FLOWERS OF EDINBURGH (R8x32) 3C (4C set) RSCDS Book 1

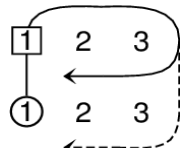
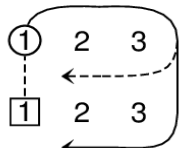
- 1- 8 1L followed by partner casts below 3s, 1L crosses and dances up behind Men as 1M dances up centre to 1st places on opposite side and 1s set
- 9-16 1M followed by partner repeat above Fig and set in own places
- 17-24 1s lead down the middle and back
- 25-32 1s+2s dance Poussette. 213

FLOWERS OF EDINBURGH			8x32 R
 <p>S</p>	 <p>S</p>		<p>1 2</p> <p>P</p>

The Ballroom, 1827, RSCDS Book 1.6

3C/4C longwise set.

EH3 7AF (J8x32) 3C (4C set) Roy Goldring RSCDS Book 40

- 1- 8 1s lead down the middle and back to top
- 9-16 1s+2s+3s Promenade ending with 1s casting to 2nd place
- 17-24 1s pass by the right and turn 1st corners RH to end L between 2s and M between 3s, 1s pass by the right and turn 2nd corners RH to end between corners
- 25-32 1M dances RH across with 2s and 1L with 3s, 1L dances up between 2s and casts to 2nd place own side as 1M dances between 3s and casts up

EH3 7AF				8x32 J	
	1 2 3 PROM	T_R	T_R	2 ① ① 3 RA	

Roy Goldring, 1998, RSCDS Book 40.6

3C/4C longwise set.

KARIN'S STRATHSPEY (S8x32) 3C (4C set) Derek Haynes Carnforth Collection 2

- 1- 8 1s+2s dance The Knot
- 9-16 1s set advancing to 1st corners, turn 2H and circle 4H round to left and end Lady between 2s facing down and Man between 3s facing up
- 17-24 1s set advancing to 2nd corners, turn 2H and circle 4H round to left and end on opposite sides facing 1st corners
- 25-32 1s dance reels of 3 on opposite sides (1s give LSh to 1st corners) and cross to own 2nd place own sides

KARIN'S STRATHSPEY				8x32 S	
1 2 KNOT	S_↑	T_B	2 ① ④ ②	③ ① 3	
S_↑	T_B				X_R

Derek Haynes, 1991, Carnforth Collection 2, RSCDS Graded Book 3.9

3C/4C longwise set.

STAIRCASE IN STYRIA (R5x40) 5C set Margaret Gray

- 1- 8 1s+2M also 3s+4M dance RH across, 1s+2L also 3s+4L dance LH across
 - 9-16 1s+4M also 3s+5M dance RH across, 1s+4L also 3s+5L dance LH across and 1L also 3L end facing out Ladies' side with partners behind them
 - 17-24 1s and 3s dance out Ladies' side and cast up 1 place, cross to Men's side and cast up to original place Ladies looping round by the right
 - 25-32 1s Cross&Cast 1 place, 1s followed by 3s dance up and cast (1s to 3rd place, 3s to 2nd place)
 - 33-40 1s Cross&Cast 1 place, 1s followed by 5s dance up and cast (1s to 5th place, 5s to 4th place) 23451
- NB - No stepping up or down until bar 27

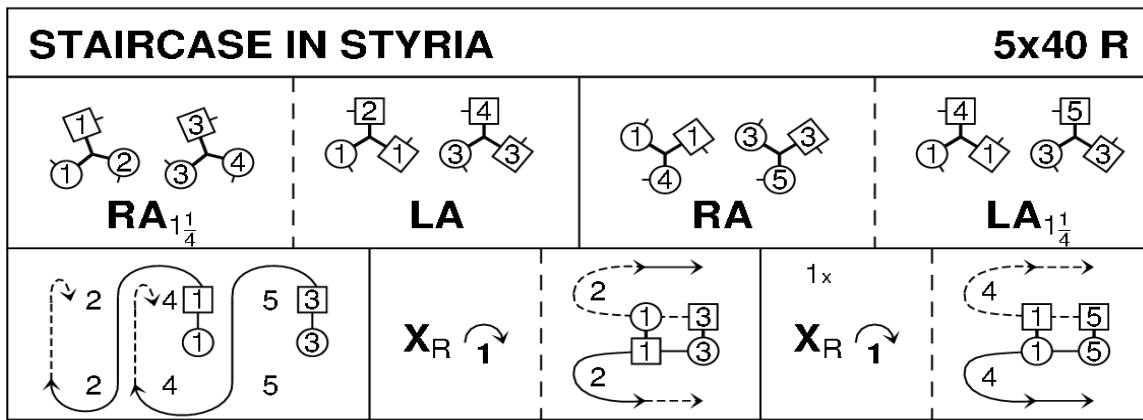

Margaret Gray

5C/5C longwise set.

IT'S ALL RIGHT (J8x32) 3C (4C set) Elma See 2nd Book Graded SCDs

- 1- 8 1s+2s+3s set and cross RH, all chase clockwise 1/2 way
- 9-16 3s+2s+1s repeat back to places
- 17-24 1s lead down the middle and back
- 25-32 1s set and cross RH, 1s cast 1 place and cross RH

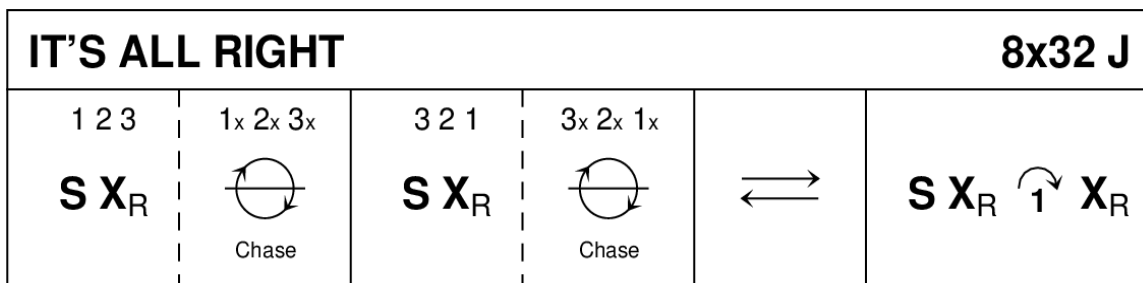

Elma See, RSCDS Graded Book 2.12

3C/4C longwise set.

BUTTERSCOTCH AND HONEY (S4x32) 4C set Jean Attwood Alexander Leaflet 24

- 1- 8 1s set and 1/2 turn RH into prom hold, 1s dance 1/2 RSh reel of 3 with 2s (2s end on opposite sides)
- 9-16 1s dance 1/2 LSh Reel of 3 with 3s and 1/2 RSh reel of 3 with 4s
- 17-24 1s followed by 4s+3s+2s cast up on opposite sides to top, cross over to own sides each Lady passing in front of partner and down own side. 2341
- 25-32 All set to partners and turn 2H into 4H round (2s with 3s and 4s with 1s)

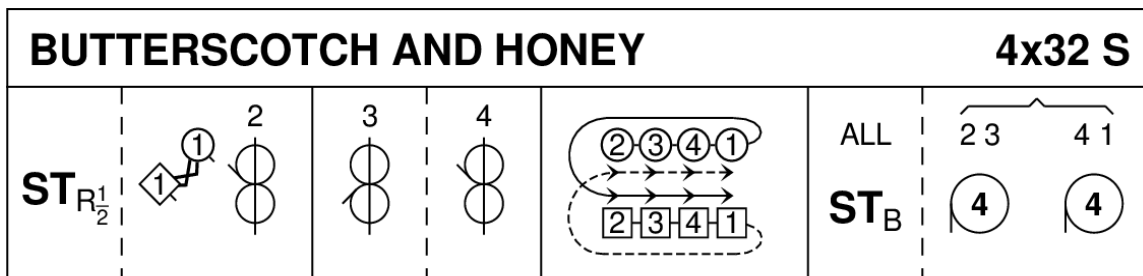

Jean Attwood, Alexander Leaflets

4C/4C longwise set

TRIP TO TIMBER RIDGE (R8X32) 3C (4C set) Linda Henderson Heart of San Francisco and RSCDS Book 52

- 1- 8 1s turn RH, cast (2s step up) then 1L+2s and 1M+3s dance RH across. 1s end facing 1st corners
- 9-16 1s dance Corner Pass&Turn with 1st corners, pass RSh and repeat with 2nd corners. 1s pull back RSh to end BtoB in centre facing opposite sides
- 17-24 2s+1s+3s dance Double Triangles. Bars 23-24 1s petronella turn to 2nd place own sides
- 25-32 2s+1s+3s circle 6H round and back

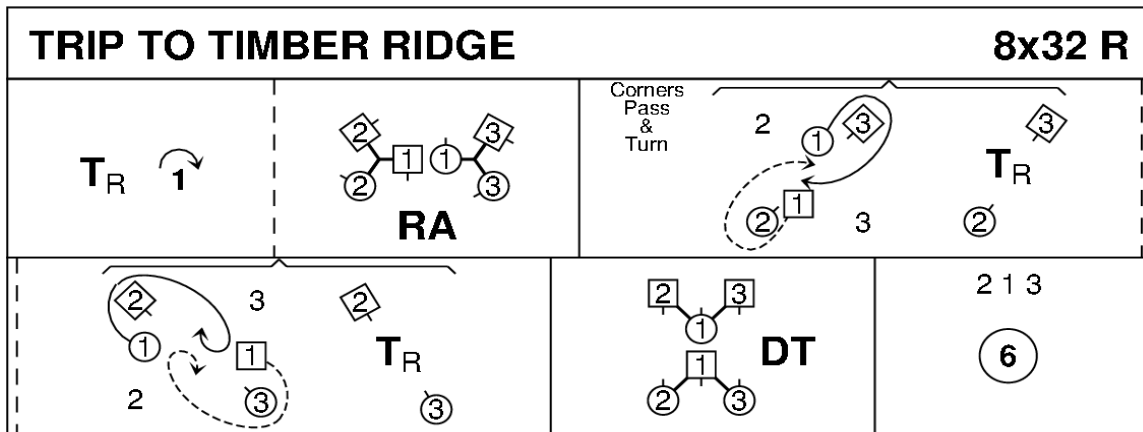

Linda Henderson, 2010, RSCDS Book 52.12

3C/4C longwise set.